

# PRODUCT OVERVIEW



**E-CLASS EVAPORATIVELY-COOLED CHILLERS**



**SMARTD**  
GLOBAL #1 IN OIL-FREE CHILLERS

## E-Class Evaporatively-Cooled Chillers

The E-Class of chillers is Smardt's evaporatively-cooled chiller that utilize Smardt's oil-free chiller technology with Turbocor's TTS compressors and R134a refrigerant. E-Class Chillers are available from 45 to 530 TR (160 to 1860 kW) and can be supplied in multiple configurations, which Smardt can customize per the requirements of your application.



A Smardt E-Class Chiller

### E-Class

Smardt has brought its extensive experience in oil-free chiller development, sales and service into designing the E-Class — an adiabatic chiller that deliver the highest level of reliability, outstanding efficiency and the lowest total cost of ownership.

E-Class chillers offer valuable benefits to owners and operators, such as ease of installation, simple streamlined operation and maintenance, and lower lifetime operating and maintenance costs. These advantages are the hallmark of Smardt chillers.

### Oil-Free Operation

Smardt oil-free centrifugal chillers use magnetic bearings and a variable-speed drive to deliver IPLV efficiencies that far surpass those of conventional oil-lubricated centrifugal, reciprocating, scroll and screw chillers.

Smardt utilizes totally oil-free Turbocor compressor technology, achieving the highest part-load efficiencies for our chillers and chilled water systems (including water-, air- and evaporatively-cooled applications).

Proprietary magnetic bearings replace conventional oil-lubricated bearings. This eliminates the high friction losses, mechanical wear, and the higher-maintenance oil management systems that are inherent with conventional compressor designs.

Turbocor's primary moving part (the rotor shaft and impellers) is levitated during rotation by a digitally controlled magnetic bearing system. Position sensors at each magnetic bearing provide real-time feedback to the bearing control system, 120 times each revolution, ensuring constantly centered rotation.

The result is oil-free operation that delivers significant chiller energy savings compared with standard chillers, and provides an extended service life without the efficiency decrease seen in oil-based systems.

### Global Number One

Smardt is the industry leader in oil-free centrifugal chillers. Smardt pioneered oil-free centrifugal compressor technology to provide plant owners and operators a line of chillers that broke through industry norms of lifetime performance, energy conservation (reducing operating expenses), streamlined maintenance, and ease of operation.

Since our first oil-free centrifugal chiller in 2002, more than 10,000 Smardt chillers, ranging from 60 TR up to 3200 TR, are now saving money, energy and CO<sub>2</sub> emissions across the globe.



# E-Class Evaporatively-Cooled Chillers



# E-Class Evaporatively-Cooled Chillers

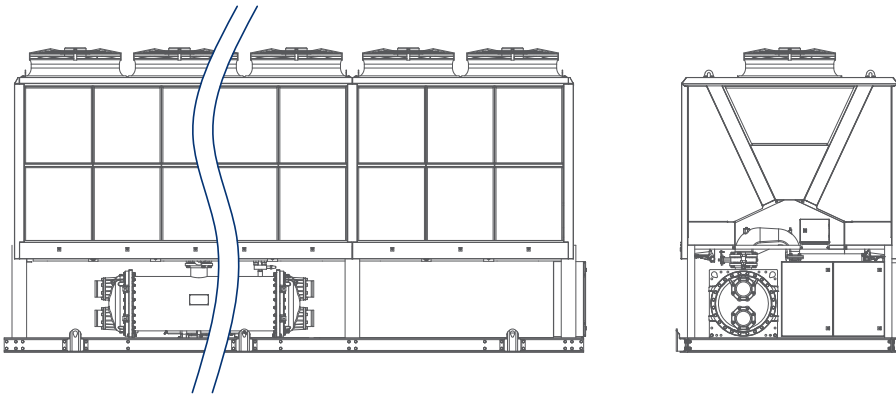

Front and side views of a Smardt E-Class EB Series chiller

## Adiabatic Operation

The E-Class chiller is Smardt's adiabatic cooling system. Cross-fluted evaporative pads are situated on the outside of the coils. Separated from the coil surface, these pads are designed to be saturated with treated water, and the pads also provide protection for the coils. Air drawn through the wetted pads is pre-cooled approximately 20-25 degrees before coming in contact with the coil surface, making the E-Class about 20% more efficient than an air-cooled chiller at full load.

Better or equal performance can be reached with lower energy consumption.

## Low Water Consumption

While Smardt's E-Class chiller can pre-cool the air before it contacts the coil, it also conserves water—especially when compared to a cooling tower's water consumption. The E-Class chiller will only activate its evaporative system when needed. During low ambient conditions, its condenser automatically switches off this evaporative system. When cooling towers support a water-cooled chiller, the cooling tower operates year-round shedding its entire heat load and consuming significantly more water.

But as with cooling towers, Smardt's E-Class chiller does require water treatment.

## Turbocor TTS Compressor

E-Class chillers can be equipped with Turbocor TTS oil-free compressors. Turbocor TTS compressors boast outstanding full-load efficiencies. VFDs are built-in, and drives are external to the machine, cooled primarily by air. These oil-free compressors have low-sound output and use environmentally friendly R134a refrigerant.



TTS Compressor

## Extended Service Life

The E-Class chiller is designed for a service life of 25 years.

## Chiller Options

Options for Smardt's E-Class chillers include our integrated pump packages, economizer, thermosyphon free cooling, Smardt Lift, and Smardt Restart.

Smardt Lift enables chiller operation at full load with enhanced efficiencies when supplying chilled water at temperatures

that are close to the ambient temperature. This is extremely beneficial in both high temperature chilled water applications or in seasonal operation when the ambient temperature is similar to the design chilled water conditions.

Smardt Restart ensures that in the event of a power failure, your Smardt chiller is back on line as quickly as 20 seconds. Chilled water supply for critical applications is not impacted by intermittent power loss, eliminating the need for additional thermal storage. The start-up mode includes additional motor and surge protection.

## Applications

Energy conscious plant owners and operators want optimized performance with savings over the life of the chiller. Smardt's E-Class chillers support critical-load applications in a variety of markets, including commercial, data center, pharmaceutical, hospital, higher education, district cooling, hotels, malls, and manufacturing.

## Highlights

- Water-cooled adiabatic efficiency when needed.
- Low water consumption.
- Ideal for dry climates.
- Typically smaller footprint than chillers of comparable capacity.
- Electronically commutated (EC) condenser fans standard.
- Designed for ease of maintenance and serviceability, featuring field-serviceable compressors.
- Responsive chilled water control under all conditions.
- Smardt quality, acceptance tested and pre-commissioned prior to delivery ensuring trouble-free commissioning and start-up on every project.



# E-Class Evaporatively-Cooled Chillers

Smardt's E-Class Evaporatively-Cooled Chillers with full-load capacities of units with R 134a refrigerant, range from 45 to 530 TR (160 to 1860 kW)

## Representative Models

Smardt can customize your E-Class chiller to meet your project's needs and specifications. The models included in this capacity chart are considered representative of the E-Class, but selection is not limited to these specific models. Your Smardt representative can provide capacity data for your project.

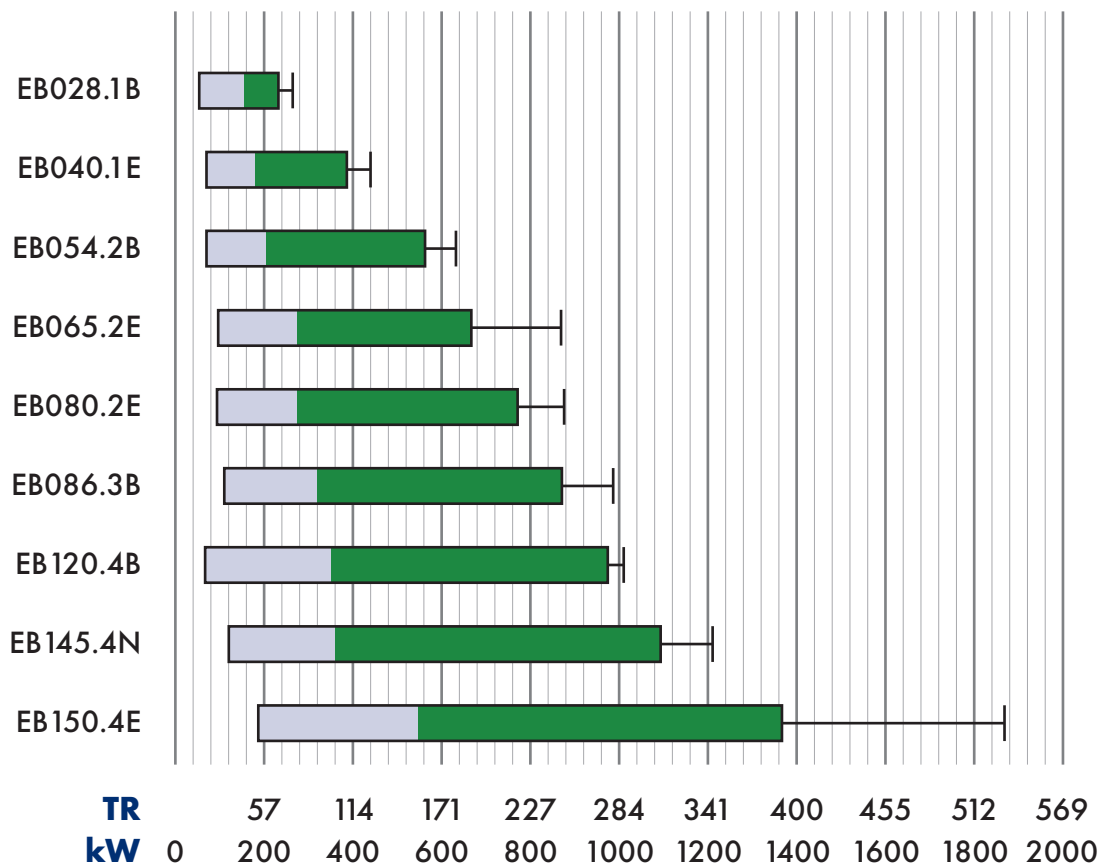

### Cooling Capacity TR (kW)



Note: Available cooling capacity will vary with operating conditions and chiller configuration. Capacities shown are based on standard AHRI conditions.

# E-Class Evaporatively-Cooled Chillers

## Model Number Nomenclature

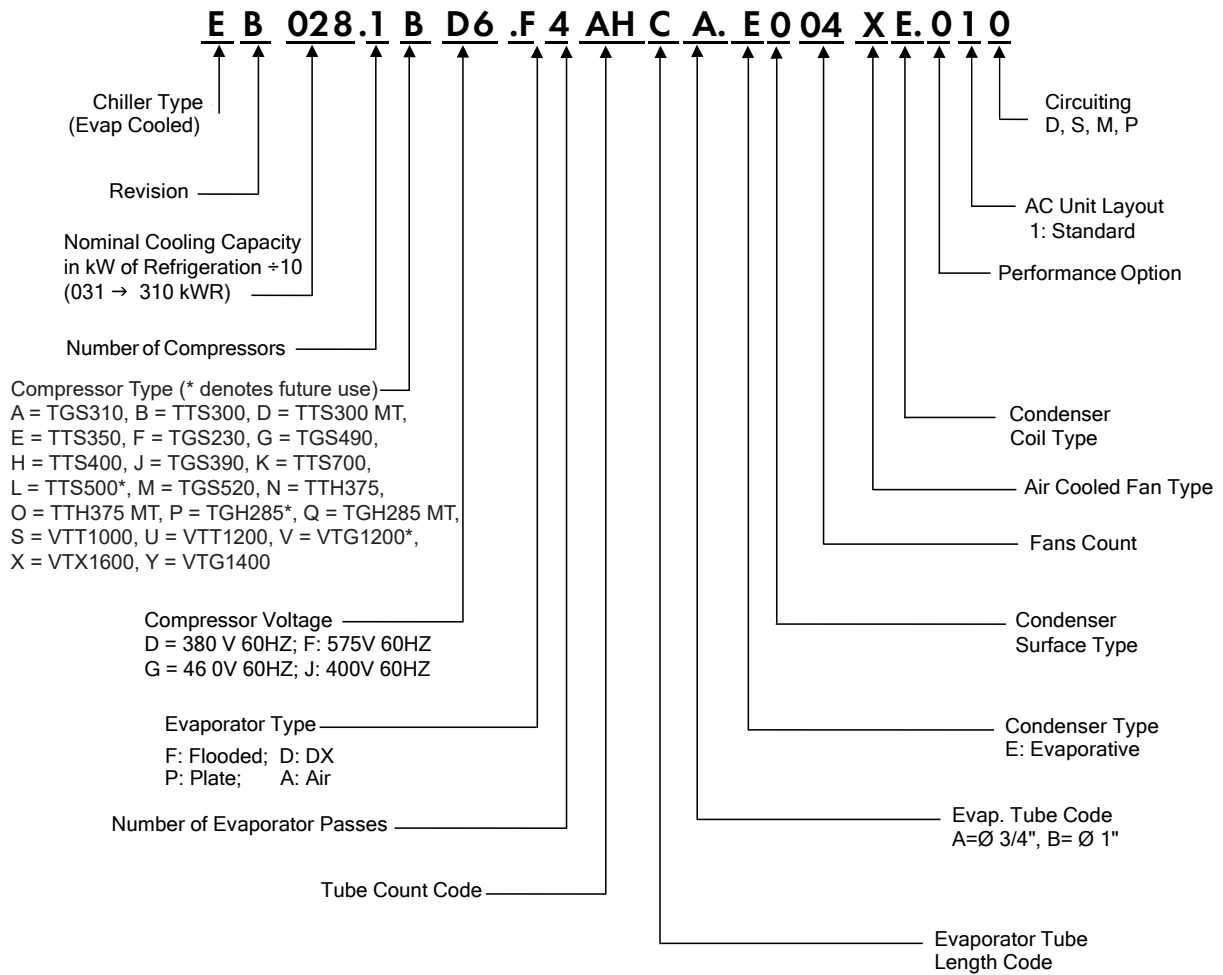

## Global reach, single focus

Smardt is both the pioneer and world-leader in oil-free centrifugal chillers, with production facilities in Canada (Montreal area), Australia (Melbourne area), United States (Plattsburgh, New York), Germany (Stuttgart area), and China (Guangzhou and Nanjing).

Smardt service networks extend across the globe to monitor and support the world's largest installed base of oil-free high-efficiency chillers, with more than 10000 chillers installed globally.



### AMERICAS

#### Canada

**Smardt Chiller Group Inc.**  
1800 Trans-Canada Highway  
Dorval, Quebec H9P1H7  
T +1 514 426 8989  
E sales.na@smardt.com

#### USA

**Smardt Chillers Inc.**  
22 Colorado Street, Bldg 2815  
Plattsburgh, NY 12903  
T +1 518 324 5741  
E sales.na@smardt.com

#### Brazil

**Mecalor Solutions (licensed partner)**  
Rua da Bandeira, 219-Novo Mundo Park  
São Paulo, Brazil  
T +55 11 2188 1700  
E vendas@mecalor.com

### ASIA PACIFIC

#### Australia

**Smardt Chiller Pty Ltd**  
144 Colchester Road  
Bayswater North VIC 3153  
T +61 3 9761 7905  
E sales.au@smardt.com

#### China

**Guangzhou Smardt Chillers  
Manufacturing Co. Ltd**  
Mei Xing Industrial Park  
No. 30 Dong Zhong Road ETDD  
Guangzhou  
T +86 20 8205 7161  
E sales.cn@smardt.com

#### Guangzhou Smardt Chillers Manufacturing Co. Ltd, Nanjing Branch No. 2,

Hengxiang Road, Qixia Economic and  
Technological Development Zone,  
Nanjing, China  
T +86 25 8532 6977  
E sales.cn@smardt.com

**TICA Smardt Hong Kong Ltd**  
11/F, The Bedford, 91-93 Bedford Road  
Tai Kok Tsui, Kowloon, Hong Kong  
T +852 2772 8448  
E hk.info@smardt.com

#### Singapore

**Smardt Chillers Pte Ltd**  
438A Alexandra Road #08-11  
Alexandra Technopark 119967  
T +65 6273 1120  
E sales.as@smardt.com

### EMEA

#### Germany

**Smardt-OPK Chillers AG**  
Bahnhofstraße 74  
D73240 Wendlingen  
T +49 7024 79429 0  
E sales.eu@smardt.com  
www.opk.de

#### United Kingdom

**Smardt Chiller UK**  
10A Burrell Way, Theford,  
Norfolk IP24 3RW  
T +44 1842 824830  
E sales.uk@smardt.com

Follow us.



[www.smardt.com](http://www.smardt.com)

Smardt has exercised its best efforts to ensure that the information contained in this document is correct at time of printing. However, no warranty, reliability or accuracy is given with respect to the information contained herein, and Smardt is not and shall not be responsible for any error or omission, or liable for the correctness or suitability of the information given. All brand names and product names used in this manual are trademarks, registered trademarks, or trade names of their respective holders.

© 2022, Smardt Chiller Group Inc. All rights reserved. 04/2022